

ESD5500E SERIES SPEED CONTROL UNIT

PRODUCT
TECHNICAL
INFORMATION

PTI 1002E

JUNE 2000

MPC

INTRODUCTION

The ESD5500E Series speed control unit is an all electronic device designed to control engine speed with fast and precise response to transient load changes. This closed loop control, when connected to a proportional electric actuator and supplied with a magnetic speed sensor signal, will control a wide variety of engines in an isochronous or droop mode. It is designed for high reliability and built ruggedly to withstand the engine environment.

Simplicity of installation and adjustment was foremost in the design. Non-interacting performance controls allow near optimum response to be easily obtained.

The primary features of the ESD5500E Series speed control unit are the engine STARTING FUEL and SPEED RAMPING adjustments. The use of these features will minimize engine exhaust smoke experienced prior to attaining engine operating speed.

Other features include adjustable droop and idle operation, inputs for accessories used in multi-engine or special applications, protection against reverse battery voltage, transient voltages, accidental short circuit of the actuator and fail safe design in the event of loss of speed sensor signal or battery supply.

The ESD5500E Series speed control unit is compatible with all GAC proportional actuators except the ACB2000 electric actuator. When the ESD5500E Series speed control unit is used with a ADC100 Series electric actuator, the DROOP adjustment range will be less due to this actuator's low current demand.

DESCRIPTION

Engine speed information for the speed control unit is usually received from a magnetic speed sensor. Any other signal generating device may be used provided the generated frequency is proportional to engine speed and meets the voltage input and frequency range specification. The speed sensor is typically mounted in close proximity to an engine driven ferrous gear, usually the engine ring gear. As the teeth of the gear pass the magnetic sensor, a signal is generated which is proportional to engine speed.

Signal strength must be within the range of the input amplifier. An amplitude of 0.5 to 120 volts RMS is required to allow the unit to function within its design specifications. The speed signal is applied to Terminals C and D of the speed control unit. Between these terminals there is an input impedance of over 33,000 ohms. Terminal D is internally connected to Terminal E, battery negative. Only one end of the shielded cable should be connected.

When a speed sensor signal is received by the controller, the signal is amplified and shaped by an internal circuit to provide an analog speed signal. If the speed sensor monitor does not detect a speed sensor signal, the output circuit of the speed control unit will turn off all current to the actuator.

A summing circuit receives the speed sensor signal along with the speed adjust set point input. The speed range has a ratio of 8:1 and is adjusted with a 25 turn potentiometer. The output from the summing circuit is the input to the dynamic control section of the speed control unit. The dynamic control circuit, of which the gain and stability adjustments are part, has a control function that will provide isochronous and stable performance for most engine types and fuel systems.

The speed control unit circuit is influenced by the gain and stability performance adjustments. The governor system sensitivity is increased with clockwise rotation of the gain adjustment. The gain adjustment has a range of 33:1. The stability adjustment, when advanced clockwise, increases the time rate of response of the governor system to match the various time constants of a wide variety of engines. The speed control unit is a P I D device, the "D", derivative portion can be varied when required. (See Instability section.)

During the engine cranking cycle, STARTING FUEL can be adjusted from an almost closed, to a nearly full fuel position. Once the engine has started, the speed control point is determined, first by the IDLE speed set point and the SPEED RAMPING circuit. After engine speed ramping has been completed, the engine will be at its governed operating speed. At the desired governed engine speed, the actuator will be energized with sufficient current to maintain the desired engine speed, independent of load (isochronous operation).

The output circuit provides switching current at a frequency of about 500 Hz. to drive the actuator. Since the switching frequency is well beyond the natural frequency of the actuator, there is no visible motion of the actuator output shaft. Switching the output transistors reduces its internal power dissipation for efficient power control. The output circuit can provide current of up to 10 amps continuous at 25°C for 12 and 24 VDC battery systems. The actuator responds to the average current to position the engine fuel control lever.

In standard operation, the speed control unit performance is isochronous. Droop governing can be selected by connecting terminals K and L and the percent of droop governing can be varied with the droop adjustment control. The droop range can be decreased by connecting Terminals G and H.

The speed control unit has several performance and protection features which enhance the governor system. A speed anticipation circuit minimizes speed overshoot on engine start-up or when large increments of load are applied to the engine. Engine idle speed can be remotely selected and is adjustable. Accessory inputs to achieve variable speed operation and multi-engine control can be accepted by the ESD5500E Series speed control unit from GAC load sharing modules, automatic synchronizers, ramp generators and other accessory engine control modules. Protection against reverse battery voltage and transient voltages is provided. The design is fail-safe in the event of loss of speed sensor signal or battery supply.

ESD 5500E SERIES SPEED CONTROL UNITS

ESD 5500E Standard Unit ESD 5520E Suitable for low inertia actuators

SPECIFICATIONS

PERFORMANCE

Isochronous Operation/Steady State Stability $\pm 0.25\%$ or better
Speed Range/Governor 1K–7.5K Hz continuous
Speed Drift with Temperature $\pm 1\%$ Maximum
Idle Adjust CW 60% of set speed
Idle Adjust CCW Less than 1200 Hz.
Droop Range 1 – 5% regulation*
Droop Adj. Max. (K-L Jumpered) 400 Hz., ± 75 Hz. per 1.0 A change
Droop Adj. Min. (K-L Jumpered) 15 Hz., ± 6 Hz. per 1.0 A change
Speed Trim Range ± 200 Hz.
Remote Variable Speed Range 500 – 7.5 Hz. or any part thereof
Terminal Sensitivity
 J 100 Hz., ± 15 Hz / Volt @ 5.0 K Impedance
 L 735 Hz., ± 60 Hz / Volt @ 65 K Impedance
 N 148 Hz., ± 10 Hz / Volt @ 1 Meg. Impedance
 P 10 VDC Supply @ 20 ma Max.

ENVIRONMENTAL

Ambient Operating Temperature Range -40° to $+180^{\circ}$ F (-40° to $+85^{\circ}$ C)
Relative Humidity up to 95%
All Surface Finishes Fungus Proof and Corrosion Resistant

INPUT POWER

Supply 12 or 24 VDC Battery Systems (Transient and Reverse Voltage Protected)**
Polarity Negative Ground (Case Isolated)
Power Consumption 50 ma continuous plus actuator current
Actuator Current Range @ 77° F (25° C) - (Inductive Load) Min. 2.5 Amps Max. 10 Amps continuous***
Speed Sensor Signal 0.5–120 Volts RMS

RELIABILITY

Vibration 1G @ 20–100 Hz.
Testing 100% Functionally Tested

PHYSICAL

Dimensions See Outline (FIGURE 1)
Weight 1.2 lbs (545 grams)
Mounting Any Position, Vertical Preferred

*Droop is based on a speed sensor frequency of 4000 Hz. and an actuator current change of 1 amp from no load to full load. Applications with higher speed sensor signals will experience less percentage of droop. Applications with more actuator current change will experience higher percentages of droop. See droop description for specific details on operation of droop ranges. When used with the ADC100 actuator the droop percentage will be less due to the actuators low current consumption.

**Protected against reverse voltage by a series diode. A 15 amp fuse must be installed in the positive battery lead.

***Protected against short circuit to actuator (shuts off current to actuator), unit automatically turns back on when short is removed.

DIAGRAM 1. ESD5500E Series Wiring Diagram and Outline

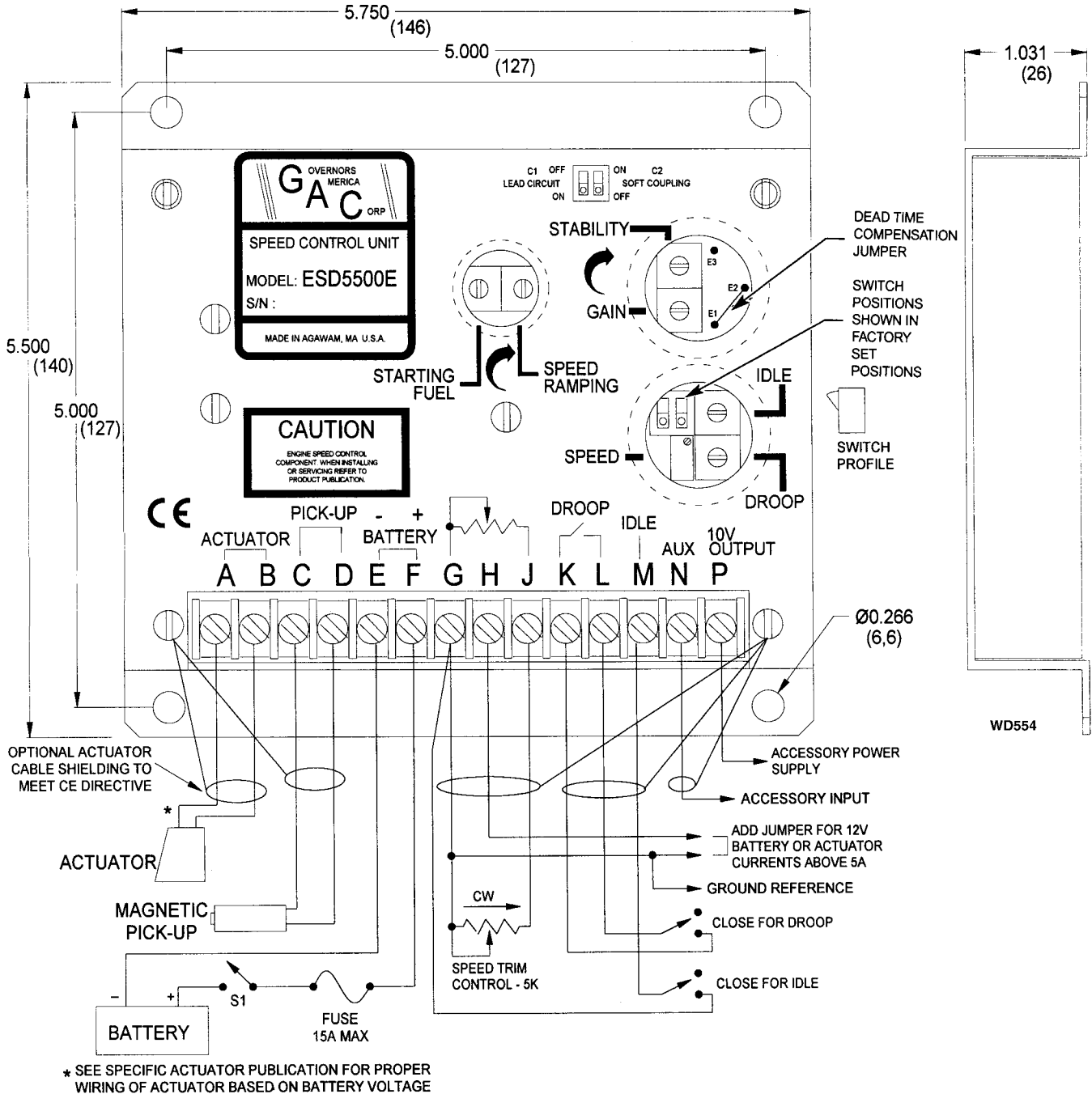

APPLICATION AND INSTALLATION INFORMATION

The speed control unit is rugged enough to be placed in a control cabinet or engine mounted enclosure with other dedicated control equipment. If water, mist, or condensation may come in contact with the controller, it should be mounted vertically. This will allow the fluid to drain away from the speed control unit.

Extreme heat should be avoided.

WARNING

An overspeed shutdown device, independent of the governor system, should be provided to prevent loss of engine control which may cause personal injury or equipment damage. Do not rely exclusively on the governor system electric actuator to prevent overspeed. A secondary shutoff device, such as a fuel solenoid must be used.

WIRING

Basic electrical connections are illustrated in Diagram 1. Actuator and battery connections to Terminals A, B, E, and F should be #16 AWG (1.3 mm sq.) or larger. Long cables require an increased wire size to minimize voltage drops.

The battery positive (+) input, Terminal F, should be fused for 15 amps as illustrated.

Magnetic speed sensor connections to Terminals C and D **MUST BE TWISTED AND/OR SHIELDED** for their entire length. The speed sensor cable shield should be ideally connected to terminal D. The shield should be insulated to insure no other part of the shield comes in contact with engine ground, otherwise stray speed signals may be introduced to the speed control unit. With the engine stopped, adjust the gap between the magnetic speed sensor and the ring gear teeth. The gap should not be any smaller than 0.020 in. (0.45 mm). Usually, backing out the speed sensor 3/4 turn after touching the ring gear tooth will achieve a satisfactory air gap. The magnetic speed sensor voltage should be at least 1 VAC RMS during cranking.

ADJUSTMENTS

Before Starting Engine

Check to insure the **GAIN** and **STABILITY** adjustments, and if applied, the external **SPEED TRIM CONTROL** are set to mid position.

Preset the ESD5500E as follows:

STARTING FUEL FULL CW (Maximum Fuel)
SPEED RAMPING FULL CCW (Fastest)

Start Engine

The speed control unit governed speed setting is factory set at approximately engine idle speed. (1000 Hz., speed sensor signal)

Crank the engine with DC power applied to the governor system. The actuator will energize to the maximum fuel position until the engine starts. The governor system should control the engine at a **low idle** speed. If the engine is unstable after starting, turn the **GAIN** and **STABILITY** adjustments counterclockwise until the engine is stable.

Governor Speed Setting

The governed speed set point is increased by clockwise rotation of the **SPEED** adjustment control. Remote speed adjustment can be obtained with an optional 5K Speed Trim Control. (See Diagram 1.)

Governor Performance

Once the engine is at operating speed and at no load, the following governor performance adjustment can be made.

A. Rotate the **GAIN** adjustment clockwise until instability develops. Gradually move the adjustment counterclockwise until stability returns. Move the adjustment one division further counterclockwise to insure stable performance.

B. Rotate the **STABILITY** adjustment clockwise until instability develops. Gradually move the adjustment counterclockwise until stability returns. Move the adjustment one division further to insure stable performance.

C. Gain and stability adjustments may require minor changes after engine load is applied. Normally, adjustments made at no load achieve satisfactory performance. A strip chart recorder can be used to further optimize the adjustments.

If instability cannot be corrected or further performance improvements are required, refer to the section on **SYSTEM TROUBLESHOOTING**.

Starting Fuel Adjustment

The engine's exhaust smoke at start-up can be minimized by completing the following adjustments.

1. Place the engine in idle by connecting Terminals M & G.
2. Adjust the **IDLE** speed for as low a speed setting as the application allows.
3. Adjust the **STARTING FUEL CCW** until the engine speed begins to fall. Increase the **STARTING FUEL** slightly so that the idle speed is returned to the desired level.
4. Stop the engine.

One of two methods of operation for the ESD5500E may now be selected.

Method 1: Start the engine and accelerate directly to the operating speed (Gen Sets, etc.).

or

Method 2: Start the engine and control at an idle speed for a period of time prior to accelerating to the operating speed. This method separates the starting process so that each may be optimized for the lowest smoke emissions.

Method 1

Remove the connection between Terminals M & G. Start the engine and adjust the **SPEED RAMPING** for the least smoke on acceleration from idle to rated speed. If the starting smoke is excessive, the **STARTING FUEL** may need to be adjusted slightly CCW. If the starting time is too long, the **STARTING FUEL** may need to be adjusted slightly CW.

Method 2

Replace the connection between Terminals M & G with a switch, usually an oil pressure switch. Start the engine. If the starting smoke is excessive, the **STARTING FUEL** may need to be adjusted slightly CCW. If the starting time is too long, the **STARTING FUEL** may need to be adjusted slightly CW.

When the switch opens, adjust the **SPEED RAMPING** for the least amount of smoke when accelerating from idle speed to rated speed.

Idle Speed Setting

If the IDLE speed setting was not adjusted as detailed in "Starting Fuel Adjustment" section, then place the optional external selector switch in the IDLE position. The idle speed set point is increased by clockwise rotation of the IDLE adjustment control. When the engine is at idle speed, the speed control unit applies droop to the governor system to insure stable operation.

Speed Droop Operation

Droop is typically used for the paralleling of engine driven generators.

Place the optional external selector switch in the DROOP position, DROOP is increased by clockwise rotation of the DROOP adjustment control. When in droop operation, the engine speed will decrease as engine load increases. The percentage of droop is based on the actuator current change from engine no load to full load. A wide range of droop is available with the internal control. Droop level requirements above 10% are unusual.

If droop levels experienced are higher or lower than those required, contact the factory for assistance.

After the droop level has been adjusted, the rated engine speed setting may need to be reset. Check the engine speed and adjust the speed setting accordingly.

Accessory Input

The AUXiliary Terminal N accepts input signals from load sharing units, auto synchronizers, and other governor system accessories, GAC accessories are directly connected to this terminal. It is recommended that this connection from accessories be shielded as it is a sensitive input terminal.

If the auto synchronizer is used alone, not in conjunction with a load sharing module, a 3 M ohm resistor should be connected between Terminals N and P. This is required to match the voltage levels between the speed control unit and the synchronizer.

When an accessory is connected to Terminal N, the speed will decrease and the speed adjustment must be reset.

When operating in the upper end of the control unit frequency range, a jumper wire or frequency trim control may be required between Terminals G and J. This increases the frequency range of the speed control to over 7000 Hz.

Accessory Supply

The + 10 volt regulated supply, Terminal P, can be utilized to provide power to GAC governor system accessories. Up to 20 ma of current can be drawn from this supply. Ground reference is Terminal G. **Caution:** a short circuit on this terminal can damage the speed control unit.

Wide Range Remote Variable Speed Operation

Simple and effective remote variable speed can be obtained with the ESD5500E Series control unit.

A single remote speed adjustment potentiometer can be used to adjust the engine speed continuously over a specific speed range. Select the desired speed range and the corresponding potentiometer value. (Refer to TABLE 1.) If the exact range cannot be found, select the next higher range potentiometer. An additional fixed resistor may be placed across the potentiometer to obtain the exact desired range. Connect the speed range potentiometer as shown in Diagram 2.

To maintain engine stability at the minimum speed setting, a small amount of droop can be added using the DROOP adjustment. At the maximum speed setting the governor performance will be near isochronous, regardless of the droop adjustment setting.

Contact the factory for assistance if difficulty is experienced in obtaining the desired variable speed governing performance.

TABLE 1. Variable Speed Range Potentiometer Value

Speed Range	Potentiometer Value
900 Hz.	1K
2,400 Hz.	5K
3,000 Hz.	10K
3,500 Hz.	25K
3,700 Hz.	50K

DIAGRAM 2.

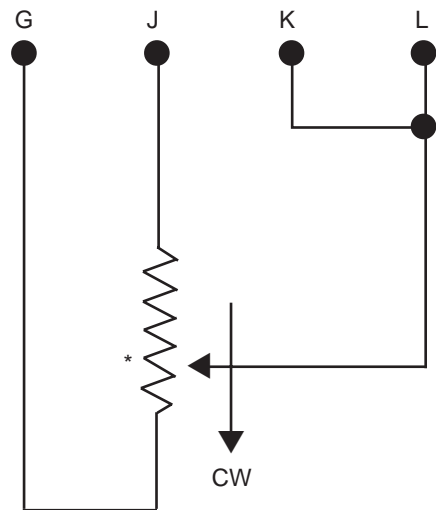

*Select Proper Potentiometer Value from Table 1.

SYSTEM TROUBLESHOOTING

SYSTEM INOPERATIVE

If the engine governing system does not function, the fault may be determined by performing the voltage tests described in Steps 1, 2, 3, and 4. (+) and (-) refer to meter polarity. Should normal values be indicated as a result of following the troubleshooting steps, the fault may be with the actuator or the wiring to the actuator. See the actuator publication for testing details.

STEP	TERMINALS	NORMAL READING	PROBABLE CAUSE OF ABNORMAL READING
1	F(+) & E(-)	Battery Supply Voltage (12 or 24 VDC)	<ol style="list-style-type: none"> DC battery power not connected. Check for blown fuse. Low battery voltage. Wiring error.
2	C & D	1.0 VAC RMS min., while cranking	<ol style="list-style-type: none"> Gap between speed sensor and gear teeth too great. Check gap. Improper or defective wiring to the speed sensor. Resistance between terminals C and D should be 30 to 1200ohms. Defective speed sensor.
3	P(+) & G(-)	10 VDC, Internal Supply	<ol style="list-style-type: none"> Short on terminal P. (This will cause a defective unit.) Defective Speed Control.
4	F(+) & A(-)	1.0 - 2.0 VDC while cranking	<ol style="list-style-type: none"> SPEED adjustment set too low. Short/open in actuator wiring. Defective speed control. Defective actuator. See Actuator Troubleshooting.

UNSATISFACTORY PERFORMANCE

If the governing system functions poorly, perform the following tests.

SYMPTOM	TEST	PROBABLE FAULT
Engine overspeeds	<ol style="list-style-type: none"> Do not crank. Apply DC power to the governor system Manually hold the engine at the desired running speed. Measure the DC voltage between Terminals A (-) & F(+) on the speed control unit. 	<ol style="list-style-type: none"> Actuator goes to full fuel. Then, disconnect speed sensor at Terminals C & D. If actuator still at full fuel – speed control unit defective. If actuator at minimum fuel position - erroneous speed signal. Check speed sensor data. If the voltage reading is 1.0 to 2.0 VDC, <ol style="list-style-type: none"> SPEED adjustment set above desired speed. Defective speed control unit. If the voltage reading is above 2.0 VDC, <ol style="list-style-type: none"> Actuator or linkage binding. If the voltage reading is below 1.0 VDC, <ol style="list-style-type: none"> Defective speed control unit. Gain set too low.
Actuator does not energize fully.	<ol style="list-style-type: none"> Measure the voltage at the battery while cranking. Momentarily connect Terminals A and F. The actuator should move to the full fuel position. 	<ol style="list-style-type: none"> If the voltage is less than 7V for a 12V system, or 14V for a 24V system, replace the battery if it is weak or undersized. Actuator or battery wiring in error. Actuator or linkage binding. Defective actuator. See actuator troubleshooting. Fuse opens. Check for short in actuator or actuator wiring harness.
Engine remains below desired governed speed.	<ol style="list-style-type: none"> Measure the actuator output. Terminals A & B, while running under governor control. 	<ol style="list-style-type: none"> If voltage measurement is within approximately 2 volts of the battery supply voltage, then fuel control restricted from reaching full fuel position. Possibly due to interference from the mechanical governor, carburetor spring or linkage alignment. Speed setting too low.

SYSTEM TROUBLESHOOTING

Insufficient Magnetic Speed Sensor Signal

A strong magnetic speed sensor signal will eliminate the possibility of missed or extra pulses. The speed control unit will govern well with 0.5 volts RMS speed sensor signal. A speed sensor signal of 3 volts RMS or greater at governed speed is recommended. Measurement of the signal is made at Terminals C and D.

The amplitude of the speed sensor signal can be raised by reducing the gap between the speed sensor tip and the engine ring gear. The gap should not be any smaller than 0.020 in (0.45 mm). When the engine is stopped, back the speed sensor out by 3/4 turn after touching the ring gear tooth to achieve a satisfactory air gap.

Electromagnetic Compatibility (EMC)

EMI SUSCEPTIBILITY – The governor system can be adversely affected by large interfering signals that are conducted through the cabling or through direct radiation into the control circuits.

All GAC speed control units contain filters and shielding designed to protect the units sensitive circuits from moderate external interfering sources.

Although it is difficult to predict levels of interference, applications that include magnetos, solid state ignition systems, radio transmitters, voltage regulators or battery chargers should be considered suspect as possible interfering sources.

If it is suspected that external fields, either those that are radiated or conducted, are or will affect the governor systems operation, it is recommended to use shielded cable for all external connections. Be sure that only one end of the shields, including the speed sensor shield, is connected to a single point on the case of the speed control unit. Mount the speed control unit to a grounded metal back plate or place it in a sealed metal box.

Radiation is when the interfering signal is radiated directly through space to the governing system. To isolate the governor system electronics from this type of interference source, a metal shield or a solid metal container is usually effective.

Conduction is when the interfering signal is conducted through the interconnecting wiring to the governor system electronics. Shielded cables and installing filters are common remedies.

As an aid to help reduce the levels of EMI of a conductive nature, a battery line filter and shielded cables are conveniently supplied by GAC in KT130. To reduce the levels of EMI of a radiated nature, a shielded container P/N CA114 can be sourced from GAC and its distributors.

In severe high energy interference locations such as when the governor system is directly in the field of a powerful transmitting source, the shielding may require to be a special EMI class shielding. For these conditions, contact GAC application engineering for specific recommendations.

Instability

Instability in a closed loop speed control system can be categorized into two general types. **PERIODIC** appears to be

sinusoidal and at a regular rate. **NON-PERIODIC** is a random wandering or an occasional deviation from a steady state band for no apparent reason.

Switch C1 controls the "Lead Circuit" found in the ESD5500. The normal position is "ON." Move the switch to the "OFF" position if there is fast instability in the system.

Switch C2 controls an additional circuit added in the ESD5500 that is designed to eliminate fast erratic governor behavior, caused by very soft or worn couplings in the drive train between the engine and generator. The normal position is "OFF." Move to the "ON" position if fast erratic engine behavior due to a soft coupling is experienced.

The **PERIODIC** type can be further classified as fast or slow instability. Fast instability is a 3 Hz. or faster irregularity of the speed and is usually a jitter. Slow periodic instability is below 3 Hz., can be very slow, and is sometimes violent.

If fast instability occurs, this is typically the governor responding to engine firings. Raising the engine speed increases the frequency of instability and vice versa. In this case, placing switch C1 in the "OFF" position will reduce the speed control unit's sensitivity to high frequency signals. Readjust the **GAIN** and **STABILITY** for optimum control. Should instability still be present, the removal of E1 to E2 jumper may help stabilize the engine. Post locations are illustrated in Diagram 1. Again, readjust the **GAIN** and **STABILITY** for optimum control. Interference from powerful electrical signals can also be the cause. Turn off the battery chargers or other electrical equipment to see if the system disappears.

Slow instability can have many causes. Adjustment of the **GAIN** and **STABILITY** usually cures most situations by matching the speed control unit dynamics. If this is unsuccessful, the dead time compensation can be modified. Add a capacitor from posts E2 to E3 (negative on E2). Post locations are illustrated in Diagram 1. Start with 10 mfd. and increase until instability is eliminated. The control system can also be optimized for best performance by following this procedure.

If slow instability is unaffected by this procedure, evaluate the fuel system and engine performance. Check the fuel system linkage for binding, high friction, or poor linkage. Be sure to check linkage during engine operation. Also look at the engine fuel system. Irregularities with carburetion or fuel injection systems can change engine power with a constant throttle setting. This can result in speed deviations beyond the control of the governor system. Adding a small amount of droop can help stabilize the system for troubleshooting.

NON-PERIODIC instability should respond to the **GAIN** control. If increasing the gain reduces the instability, then the problem is probably with the engine. Higher gain allows the governor to respond faster and correct for disturbance. Look for engine misfirings, an erratic fuel system, or load changes on the engine generator set voltage regulator. If the throttle is slightly erratic, but performance is fast, move switch C1 to the "OFF" position. This will tend to steady the system.

If unsuccessful in solving instability, contact the factory for assistance.