



DEEP SEA ELECTRONICS

# 500 AUTO TRANSFER SWITCH

Issue 4  
VH 03/04/03

## DESCRIPTION

The 500 is an **automatic transfer switch control module**, designed to monitor the incoming AC mains supply (3 phases) for under voltage.

Should the voltage fall out of limits, the module will issue a start command to the generating set controller. Once the set is available, the ATS module will control the transfer devices and switch the load from the mains to the generating set. Should the mains supply return to within limits the module will command a return to the mains supply and stop requesting the generator.

A clear **mimic diagram** with 'International' symbols and LED indications provide 'at a glance' information as to supply availability and load switching status.

In the event of a mains failure the module operation would normally be as follows:

**'Mains available' LED** extinguishes and the module de-energises the **'Run Generator' Relay**, causing the **'Run' contacts** to close. A generator start module receives this signal and initiates the engine start.

Once the generator is running and the **'Engine Running' signal** is present, the **'Generator available' LED** will illuminate. The module will then await the 'Load transfer' signal from the generator controller, once this is present the Module will then energise the **'Close mains' relay** which causes the **'Close mains' contacts** to open, thus opening the mains contactor. The **'Mains on load' LED** will extinguish. After a short time delay, (**Transfer Delay 0.7**) allowing the mains contactor to open, the **'Close generator' relay** is energised causing the **'Close generator' contacts** to close, thus causing the generator contactor to close. The **'Generator on load' LED** will illuminate.

Should the mains supply return to within limits the **'Mains Available' LED** will illuminate and the module will energise the 'Run Generator' Relay causing the 'Run' contacts to open, on removal of the **'Load transfer' signal** the **'Generator Close' relay** will de-energise and the **'Generator Close' contacts** will open. The **'Generator On load' LED** will extinguish. Following the **'transfer delay'** the module will de-energise the **'Mains close' relay** and the **'Close mains' contacts** will close. The **'Mains On Load' LED** will illuminate. When the 'Engine Running' signal is removed the module will then extinguish the 'Generator Available' LED. The module will then await the next mains failure event.

The 500 ATS module is intended for use with the DSE 52x range of Remote Start controllers. The 'RUN' contacts connect to the 'Remote Start' input, and 'ENGINE RUNNING' and 'LOAD TRANSFER' are fed from relay outputs on the 52x configured accordingly. Sequence timers (Start Delay, Warm-up, Stop Delay and Cooling) are configured in the 52x module.

Although designed for use with DSE engine controllers, the flexibility of the module also allows it to be connected directly to a range of commercially available, and custom built, generator control systems.

The module is mounted in a robust plastic case. Connection to the module is via plug and socket connectors



## SPECIFICATION

### DC Supply:

The module DC is powered from the plant battery or from a low voltage supply between 8 to 35V Continuous. It is able to operate at 0V for 50ms during cranking, providing supply was at least 10V before dropout and supply recovers to 5V. This is achieved without the need for internal batteries.

### Max. Operating Current:

85mA @ 12V, 92mA @ 24V.

### 1 Low Voltage Auxilliary Relay Contact:

5Amp DC rated - NC connected internally to -Ve.

### 2 Mains Rated Relay Contacts:

8Amp RMS rated 1 of each - NO (Voltage Free)  
NC (Voltage Free)

### Dimensions:

72mm x 72mm x 76mm  
2.8" x 2.8" x 3.0"

### Operating Temperature Range:

-25 to +55°C

### Indications:

Mains Available LED (Green)  
Mains on Load LED (Amber)  
Generator Available LED (Green)  
Generator On load LED (Amber)

### Operating Voltage:

100-300V NOMINAL RMS Input Range.

Mains Trip 75V-275V AC RMS (Adjusted via a potentiometer accessible from the rear of the module.)

### Transfer Delay :

0.8Sec (+/- 0.1sec) (Fixed)

## CASE DIMENSIONS

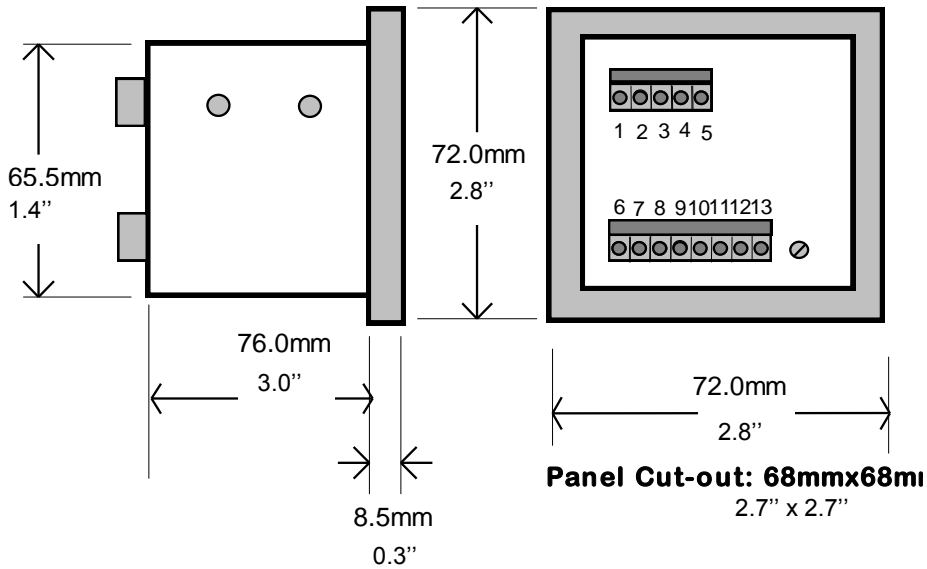

## TYPICAL CONNECTIONS

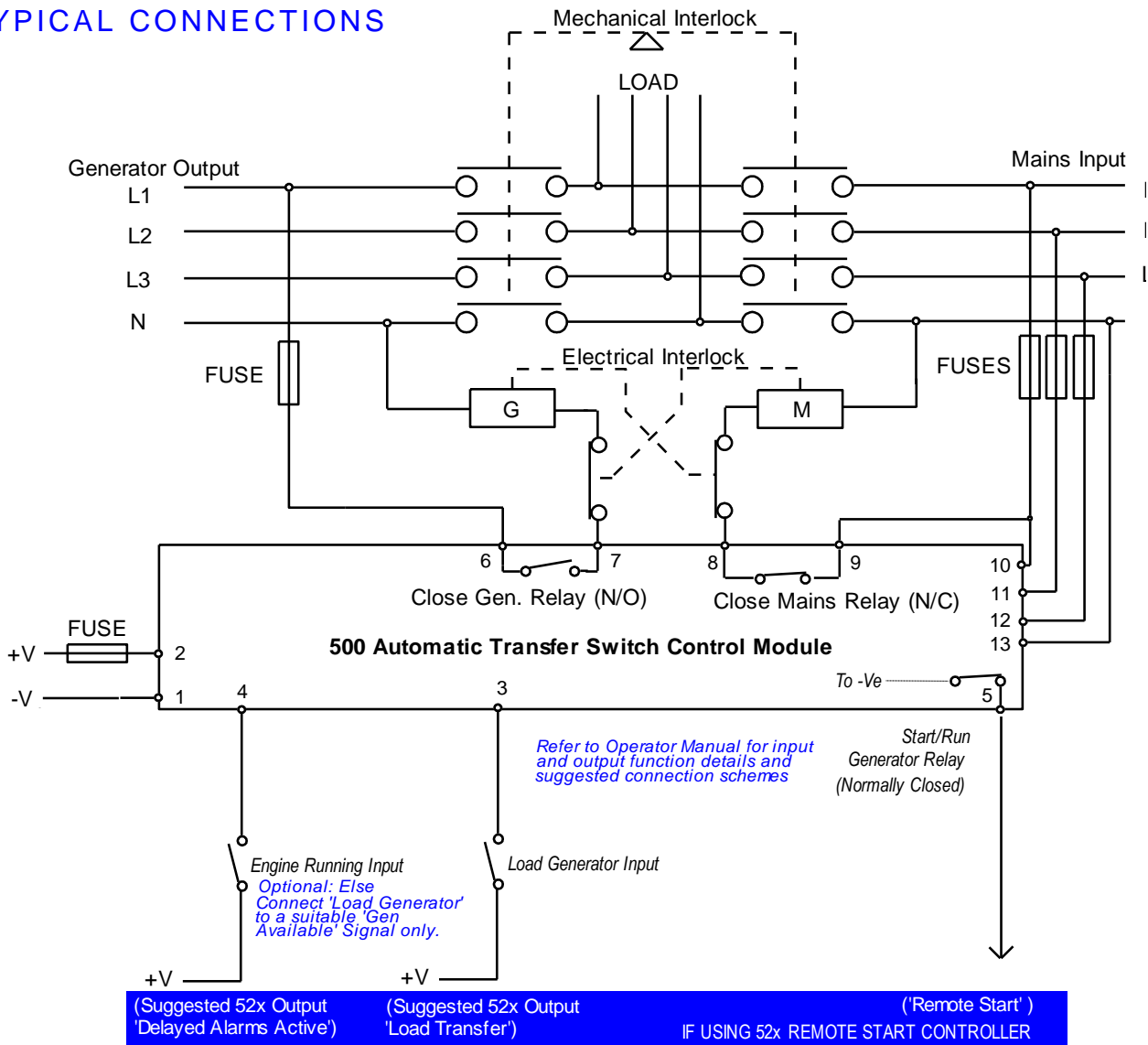

**Deep Sea Electronics Plc.**  
Highfield House, Hunmanby Industrial Estate,  
North Yorkshire, YO14 0PH, ENGLAND  
Tel +44 (0)1723 890099.  
Fax +44 (0)1723 893303.  
Email - sales@deepseapl.com  
Web - www.deepseapl.com

**Deep Sea Electronics inc.**  
5301 E. State St. – Suite 202  
Rockford, Illinois 61108 U.S.A.  
Phone +1 (815) 316-8706  
Fax +1 (815) 316-8708  
Email – dsesales@deepseausa.com  
Web – www.deepseausa.com